

MURRAY

MURRAY CORPORATION Clamping Solutions

Type "F" Quick Release Clamp

Band and housing are 200 Series Stainless Steel with a 200 Series Stainless screw. These quick release worm drive clamps are easy to install and remove due to the swivel action locking of the screw. This clamp has a large clamping range which makes them very versatile. It is used for closed system installations where the clamp must be opened to be fitted.

Part Number	Diameter (Inch)		Diameter (mm)	
	Open	Closed	Open	Closed
QR 104 S2	7.00	2.00	171	51
QR 128 S2	8.50	2.00	216	51
QR 152 S2	10.00	2.00	254	51
QR 188 S2	12.25	2.00	311	51
QR 232 S2	15.00	2.00	381	51
QR 258 S2	16.63	2.00	422	51
QR 288 S2	18.50	2.00	470	51
QR 312 S2	20.00	2.00	508	51

Other sizes available

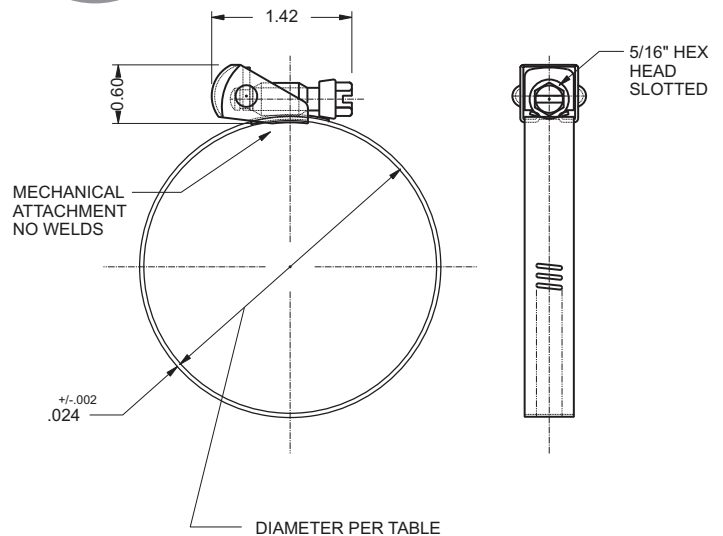
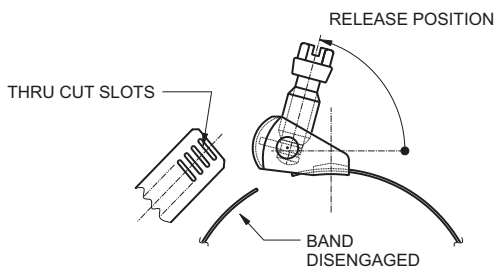
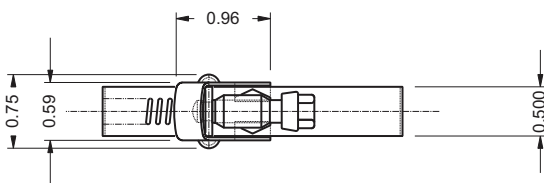

260 Schilling Circle
Hunt Valley, MD, 21031, USA

Ph: 410-771-0380 • Fax: 410-771-5576
www.murraycorp.com • email: sales@murraycorp.com

